

## 3 in 1 Magnetic Wireless Charging Station User Manual

### Preface:

Thank you for purchasing our 3-in-1 Magnetic Wireless Charger. Read this manual carefully before use, and retain it for future reference.

### Specification:

Product interface: type-C, cable, charger included

Material: ABS+Stainless steel

Input : 9V 2A 12V 1.5A

Apple watch output power: 3W(Max)

Airpods charging power: 5W(Max)

Apple phone charging power: 7.5W(Max)

Product color: black

### Compatible Devices:

(Magnetic)iPhone 15 Pro Max/15 Pro/15 Plus/15/14 Pro Max/14 Pro/14 Plus/14/13 Pro Max/13 Pro/13/ 13 mini/12 Pro Max/12 Pro/12/12 mini

Apple Watch Series Ultra 2/9/8/Ultra/SE 2/7/6/SE/5/4/3/2 AirPods Pro 2/AirPods 3/AirPods Pro/AirPods 2

### Product Overview

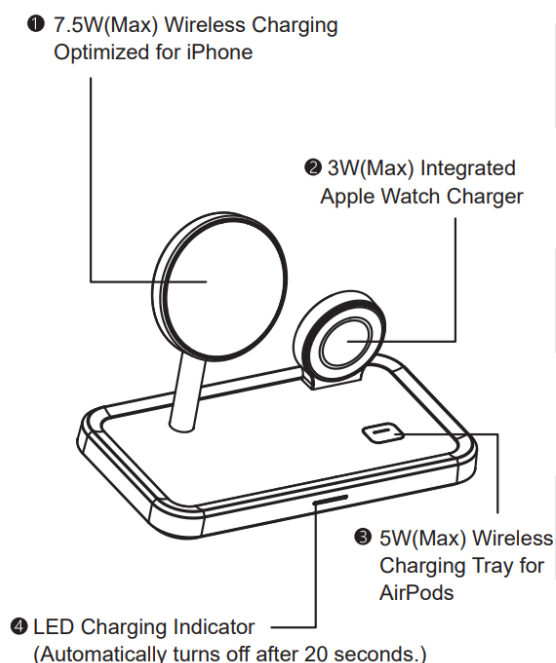

1. 7.5W(Max) Wireless Charging Optimized for iPhone
2. 3W(Max) Integrated Apple Watch Charger
3. LED Charging Indicator (Automatically turns off after 20 seconds.)
4. 5W(Max) Wireless Charging Tray for AirPods

### Product display:

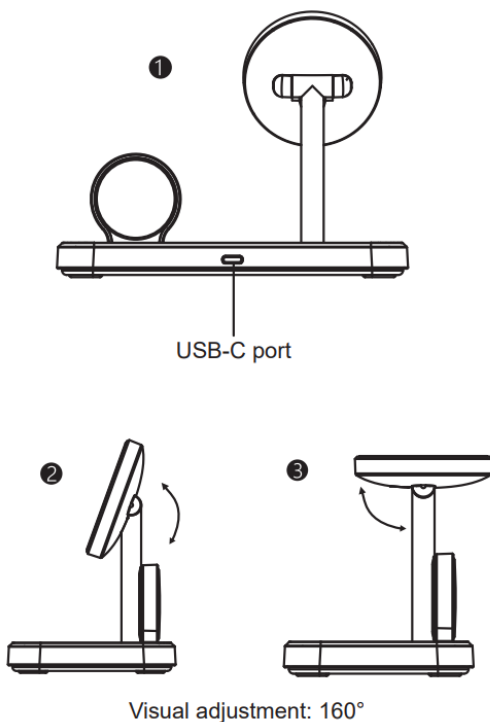

1. USB-C Port
2. Visual adjustment: 160°
3. Visual adjustment: 160°

### Important Safety Instructions

Before Using the unit, please read the user manual carefully.

- Do not store device in high-temperature environment, including heat caused by intense sunlight or other forms of heat.
- Do not place device in fire or other excessively hot environments. Exposure to fire or temperature above 212°F(100C) may

cause explosion.

- Do not use the wireless charger in excess of its output rating. Over loading outputs above rating may result in a risk of fire or injury to persons.
- Do not expose the wireless charger to rain or snow.
- Do not modify, repair or disassemble the unity, if so, please contact the manufacturer.
- Switch off the wireless charger when not in use. The wireless charger will automatically switch off when disconnected from its wall charger.

### Q&A

When I place the phone on the charger, it starts charging, but after a few minutes it stops and the light starts to flash. Why?

- 1. Make sure your device supports the Qi wireless charging function before using this wireless charger.
- 2. Check if you are using the QC 3.0 adapter to power our wireless charger, or test with another adapter.
- 3. Test with other USB cables.
- 4. Check whether your device's case contains metal.

Magnetic and metal attachments will cause an LED flash and prevent charging. If the phone has a case,

please make sure the thickness is less than 0.2 in or remove the case before charging.

- 5. Please place the phone correctly. If the phone is placed in the incorrect position, it will affect charging.
- 6. Restart your phone

### FCC WARNING

This device complies with part 15 of the FCC Rules.

Operation is subject to the following two Conditions:

- (1) this device may not cause harmful interference, and
- (2) this device must accept any interference received, including interference that may

cause undesired operation. Any changes or modifications not expressly approved by the party responsible for compliance could void the user's authority to operate the equipment.

NOTE:

This equipment has been tested and found to comply with the limits for a Class B digital device, pursuant to Part 15 of the FCC Rules. These limits are digital device, pursuant to Part 15 of the FCC Rules. These limits are designed to provide reasonable protection against harmful interference in a residential installation. This equipment generates, uses and can radiate radio frequency energy and, if not installed and used in accordance with the instructions, may cause harmful interference to radio communications. However, there is no guarantee that interference will not occur in a particular installation.

If this equipment does cause harmful interference to radio or television reception, which can be determined by turning the equipment off and on, the user is encouraged to try to correct the interference by one or more of the following measures:

- Reorient or relocate the receiving antenna.
- Increase the separation between the equipment and receiver.
- Connect the equipment into an outlet on a circuit different from that to which the receiver is connected.
- Consult the dealer or an experienced radio/TV technician for help.

To maintain compliance with FCC's RF Exposure guidelines, this equipment should be installed and operated with minimum distance between 20cm the radiator your body: Use only the supplied antenna.

This device was tested for typical mobile type device operations. To comply with R F exposure requirements, a minimum separation distance of 20cm must be

maintained between the user's body and the handset, including the antenna. Third party belt clips, holsters, and similar accessories used by this device should not contain any metallic components. mobile type device accessories that do not meet these requirements may not comply with RF exposure requirements and should be avoided.

Use only the supplied or an approved antenna.

This device in compliance with the essential requirements and other relevant provisions of Radio Equipment Directive (RED) SI 2017 No.1206. All essential radio test suites have been carried out.

The device complies with RF specifications when the device used at 20cm form your body.

#### **Why can't I charge my AirPods 2?**

- 1. Make sure your device supports the wireless charging function.
- 2. AirPods 2 is divided into two series; one supports wireless charging and the other cannot support wireless charging.
- 3. When your AirPods 2 has an indicator on the outside of the shell, it can support wireless charging. When your AirPods 2's indicator is inside the clamshell, it can't support wireless charging.
- 4. You can confirm by contacting the customer service.